



JOB NO. E-11-265829
Date: 22/11/2017

Civil & Structural Engineering Design Services Pty. Ltd.



Civil & Structural Engineering Design Services Pty. Ltd.

Client: Easy Signs Pty. Ltd.

Project: Design check – 3m × 3m, 3m × 4.5m & 3m × 6m Folding Marquees for Pop-up Gazebos for 45km/hr Wind Speed

Reference: Easy Signs Pty. Ltd. Technical Data

Report by: KZ
Checked by: EAB
Date: 22/11/2017

JOB NO: E-11-265829



Civil & Structural Engineering Design Services Pty. Ltd.

Table of Contents

1	Introduction	4
2	Design Restrictions and Limitations.....	5
3	Specifications.....	6
3.1	General.....	6
3.2	Section Properties	7
4	Design Loads	7
4.1	Ultimate	7
4.2	Load Combinations.....	7
4.2.1	Serviceability	7
4.2.2	Ultimate	7
5	Wind Analysis.....	7
5.1	Parameters.....	7
5.2	Pressure Coefficients (C_{fig}).....	8
5.2.1	Pressure summary	10
5.3	Wind Load Diagrams.....	11
5.3.1	Wind 1(case 1).....	11
5.3.2	Wind 1(case 2).....	11
5.3.3	Wind 2(Case1)	12
5.3.4	Wind 2(case 2).....	12
5.3.5	Max Bending Moment due to critical load combination in major axis.....	13
5.3.6	Max Bending Moment in minor axis due to critical load combination.....	13
5.3.7	Max Shear in due to critical load combination.....	14
5.3.8	Max Axial force in upright support and roof beam due to critical load combination	14
5.3.9	Max reactions.....	15
6	Checking Members Based on AS1664.1 ALUMINUM LIMIT STATE DESIGN	15
6.1	Scissors Beam	15
6.2	Upright Supports (outer).....	19
7	Summary	24
7.1	Conclusions.....	24
8	Appendix A – Base Anchorage Requirements.....	25



Civil & Structural Engineering Design Services Pty. Ltd.

1 Introduction

This Certification is the sole property for copyright of Mr. Ted Bennett of Civil & Structural Engineering Design Services Pty. Ltd. and the license holder for the exclusive use of this Certification, Easy Signs Pty Ltd.

The following structural drawings and calculations are for the applicable transportable tents supplied Easy Signs Pty Ltd.

The report examines the effect of 3s gust wind of 45 km/hr on 3m x6 m Folding Marquees for Pop-up Gazebos as the worst-case scenario. The relevant Australian Standards AS1170.0:2002 General principles, AS1170.1:2002 Permanent, imposed and other actions and AS1170.2:2011 Wind actions are used. The design check is in accordance with AS/NZS 1664.1 Aluminum Limit State Design.



Civil & Structural Engineering Design Services Pty. Ltd.

2 Design Restrictions and Limitations

- 2.1 The erected structure is for temporary use only.
- 2.2 It should be noted that if high gust wind speeds are anticipated or forecast in the locality of the tent, the temporary erected structure should be folded.
- 2.3 For forecast winds in excess of (**refer to summary**) the structure should be completely folded.
(Please note that the locality squall or gust wind speed is affected by factors such as terrain exposure and site elevations.)
- 2.4 The structure may only be erected in regions with wind classifications no greater than the limits specified on the attached wind analysis.
- 2.5 The wind classifications are based upon category 2 in AS. Considerations have also been made to the regional wind terrain category, topographical location and site shielding from adjacent structures. Please note that in many instances topographical factors such as a location on the crest of a hill or on top of an escarpment may yield a higher wind speed classification than that derived for a higher wind terrain category in a level topographical region. For this reason, particular regard shall be paid to the topographical location of the structure. For localities which do not conform to the standard prescribed descriptions for wind classes as defined above, a qualified Structural Engineer may be employed to determine an appropriate wind class for that the particular site.
- 2.6 The structures in no circumstances shall ever be erected in tropical or severe tropical cyclonic condition.
- 2.7 The tent structure has not been designed to withstand snow and ice loadings such as when erected in alpine regions.
- 2.8 For the projects, where the site conditions approach the design limits, extra consideration should be given to pullout tests of the stakes and professional assessment of the appropriate wind classification for the site.
- 2.9 Design of fabric is by others.
- 2.10 No Fabrics or doors should be used for covering the sides of unbraced Folding Marquees due to the lack of bracing within the system and insufficient out-of-plane stiffness of framing.**



3 Specifications

3.1 General

Tent category	
Material	Aluminum 6061T6

Size	Model
3m x 6m	Folding Marquees

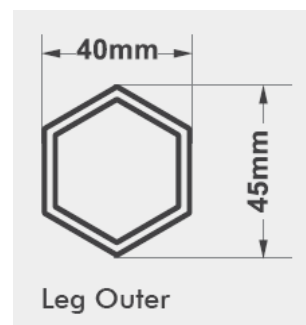
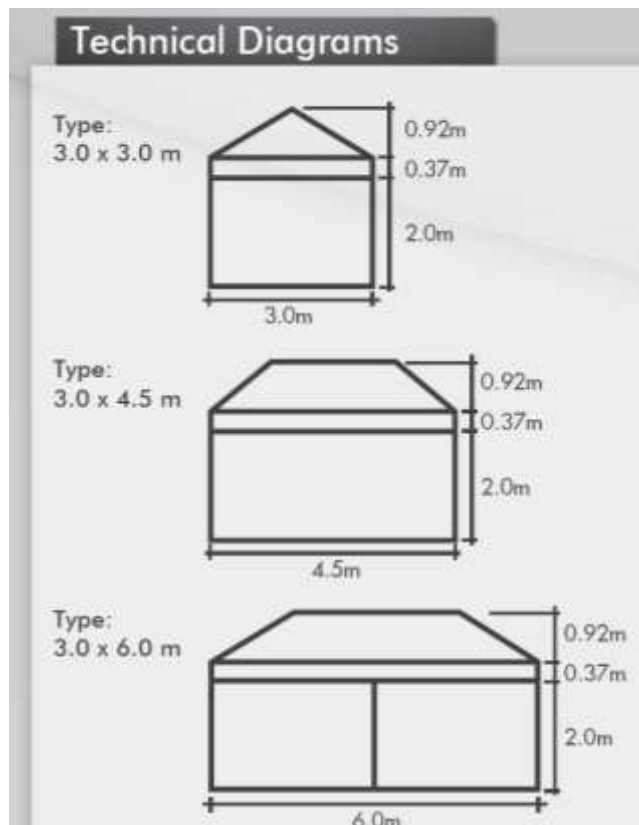
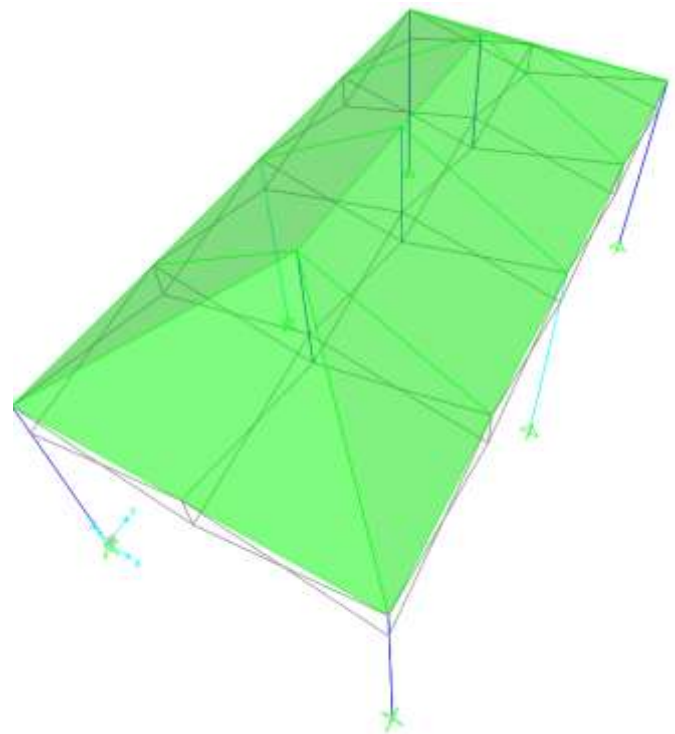



3.2 Section Properties

MEMBER(S)	Section	b	d	t	y _c	A _g	Z _x	Z _y	S _x	S _y	I _x	I _y	J	r _x	r _y
		mm	mm	mm	mm	mm ²	mm ³	mm ³	mm ³	mm ³	mm ⁴	mm ⁴	mm ⁴	mm	mm
Truss Bar	25x12.5x1	12.5	25	1	12.5	71.0	450.4	296.0	564.5	342.6	5629.9	1850.2	4291.6	8.9	5.1
Upright Support	HEX 45x40x1	45	40	1	20.0	135.1	1236.6	1427.9	1774.9	1756.7	28558.6	28558.6	51812.5	14.5	14.5

4 Design Loads

4.1 Ultimate

		Distributed load (kPa)	Design load factor (-)	Factored imposed load (kPa)
Live	Q	-	1.5	-
Self weight	G	self weight	1.35, 1.2, 0.9	1.2 self weight, 0.9 self weight
3s 45km/hr gust	W	0.078 C _{fig}	1.0	0.078 C _{fig}

4.2 Load Combinations

4.2.1 Serviceability

Gravity = $1.0 \times G$

Wind = $1.0 \times G + 1.0 \times W$

4.2.2 Ultimate

Downward = $1.35 \times G$
= $1.2 \times G + W_u$

Upward = $0.9 \times G + W_u$

5 Wind Analysis

Wind towards surface (+ve), away from surface (-ve)

5.1 Parameters

Terrain category = 2

Site wind speed ($V_{sit,\beta}$) = $V_R M_d (M_{z,cat} M_s M_t)$

$V_R = 12.50\text{m/s}$ (45 km/hr)

(regional 3 s gust wind speed)

$M_d = 1$

$M_s = 1$

$M_t = 1$

$M_{z,cat} = 0.91$

(Table 4.1(B) AS1170.2)



Civil & Structural Engineering Design Services Pty. Ltd.

$V_{sit,\beta} = 11.38 \text{ m/s}$

Height of structure (h) = 2.8 m (mid of peak and eave)
 Width of structure (w) = 3 m
 Length of structure (l) = 6 m
 Pressure (P) = $0.5\rho_{air} (V_{sit,\beta})^2 C_{fig} C_{dyn}$
 = 0.078 C_{fig} kPa

5.2 Pressure Coefficients (C_{fig})

Name	Symbol	Value	Unit	Notes	Ref.
Input					
Importance level		2			Table 3.1 - Table 3.2 (AS1170.0)
Annual probability of exceedance		Temporary			Table 3.3
Regional gust wind speed		45	Km/hr		Table 3.1 (AS1170.2)
Regional gust wind speed	V_R	12.50	m/s		
Wind Direction Multipliers	M_d	1			Table 3.2 (AS1170.2)
Terrain Category Multiplier	$M_{z,cat}$	0.91			Table 4.1 (AS1170.2)
Shield Multiplier	M_s	1			4.3 (AS1170.2)
Topographic Multiplier	M_t	1			4.4 (AS1170.2)
Site Wind Speed	$V_{Site,\beta}$	11.38	m/s	$V_{Site,\beta} = V_R * M_d * M_{z,cat} * M_s * M_t$	
Pitch	α	30	Deg		
Pitch	α	0.52	rad		
Width	B	-	m		
Length	D	-	m		
Height	Z	2.8	m		
Wind Pressure					
ρ_{air}	ρ	1.2	Kg/m ³		
dynamic response factor	C_{dyn}	1			
Wind Pressure	$\rho * C_{fig}$	0.078	Kg/m ²	$\rho = 0.5\rho_{air} * (V_{des,\beta})^2 * C_{fig} * C_{dyn}$	2.4 (AS1170.2)
WIND DIRECTION 1 ($\theta=0$)					
External Pressure					
4. Free Roof				$\alpha = 0^\circ$	



Civil & Structural Engineering Design Services Pty. Ltd.

Area Reduction Factor	K_a	1			D7
local pressure factor	K_l	1			
porous cladding reduction factor	K_p	1			
External Pressure Coefficient MIN	$C_{p,w}$	-0.3			
External Pressure Coefficient MAX	$C_{p,w}$	0.8			
External Pressure Coefficient MIN	$C_{p,l}$	-0.7			
External Pressure Coefficient MAX	$C_{p,l}$	0			
aerodynamic shape factor MIN	$C_{fig,w}$	-0.30			
aerodynamic shape factor MAX	$C_{fig,w}$	0.80			
aerodynamic shape factor MIN	$C_{fig,l}$	-0.70			
aerodynamic shape factor MAX	$C_{fig,l}$	0.00			
Pressure Windward MIN	P	-0.02	kPa		
Pressure Windward MAX	P	0.06	kPa		
Pressure Leeward MIN	P	-0.05	kPa		
Pressure Leeward MAX	P	0.00	kPa		

WIND DIRECTION 2 ($\theta=90$)
External Pressure

4. Free Roof				$\alpha=180^\circ$	D7
Area Reduction Factor	K_a	1			
local pressure factor	K_l	1			
porous cladding reduction factor	K_p	1			
External Pressure Coefficient MIN	$C_{p,w}$	-0.3			
External Pressure Coefficient MAX	$C_{p,w}$	0.4			
External Pressure Coefficient MIN	$C_{p,l}$	-0.4			
External Pressure Coefficient MAX	$C_{p,l}$	0			
aerodynamic shape factor MIN	$C_{fig,w}$	-0.30			
aerodynamic shape factor MAX	$C_{fig,w}$	0.40			
aerodynamic shape factor MIN	$C_{fig,l}$	-0.40			
aerodynamic shape factor MAX	$C_{fig,l}$	0.00			
Pressure MIN (Windward Side)	P	-0.02	kPa		
Pressure MAX (Windward Side)	P	0.03	kPa		
Pressure MIN (Leeward Side)	P	-0.03	kPa		
Pressure MAX (Leeward Side)	P	0.00	kPa		



Civil & Structural Engineering Design Services Pty. Ltd.

5.2.1 Pressure summary

WIND EXTERNAL PRESSURE	Direction1		Direction2		
	Min (Kpa)	Max (Kpa)		Min (Kpa)	Max (Kpa)
W	-0.02	0.06	W	-0.02	0.03
L	-0.05	0.00	L	-0.03	0.00

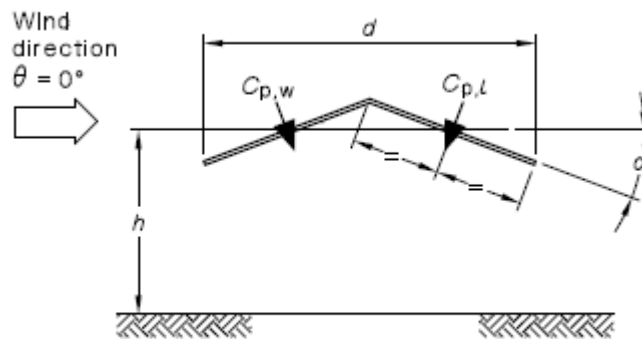
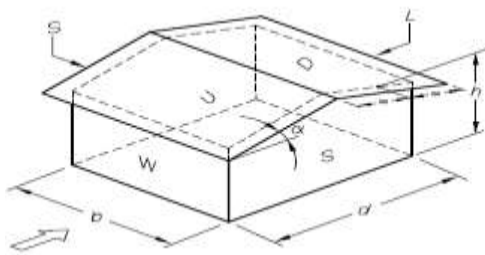
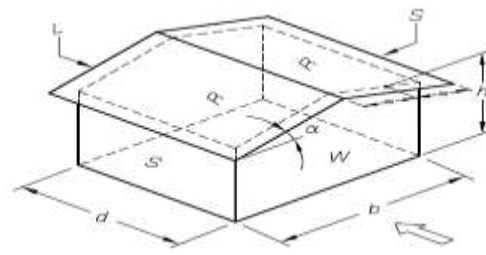

FIGURE D3 PITCHED FREE ROOFS



Direction 1



Direction 2

AS1170.2



Civil & Structural Engineering Design Services Pty. Ltd.

5.3 Wind Load Diagrams

5.3.1 Wind 1(case 1)

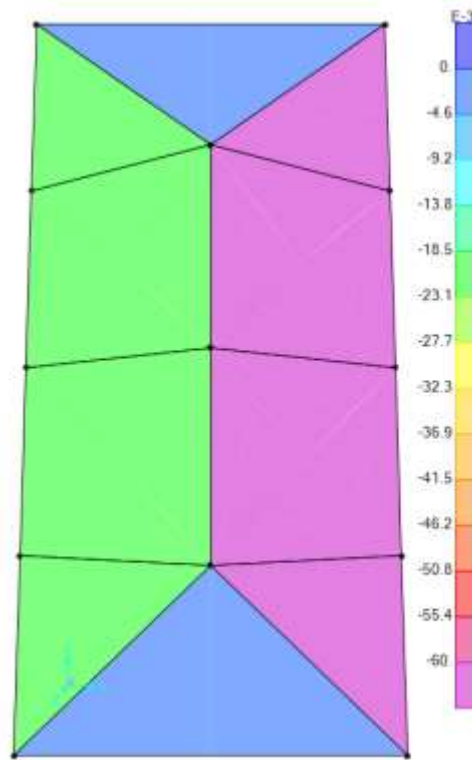

5.3.2 Wind 1(case 2)

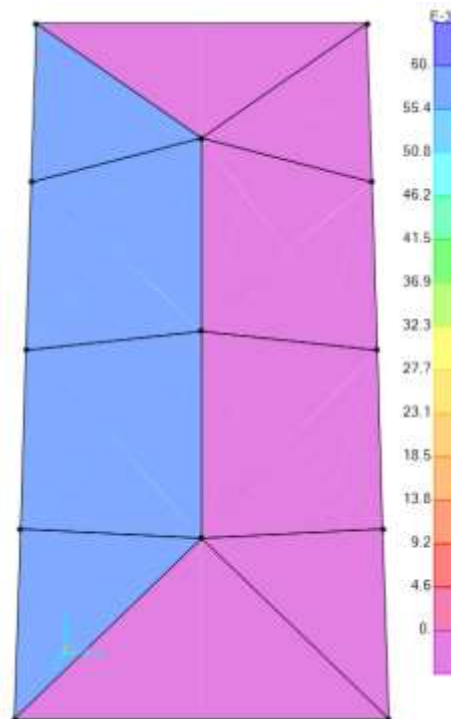



Civil & Structural Engineering Design Services Pty. Ltd.

5.3.3 Wind 2(Case1)

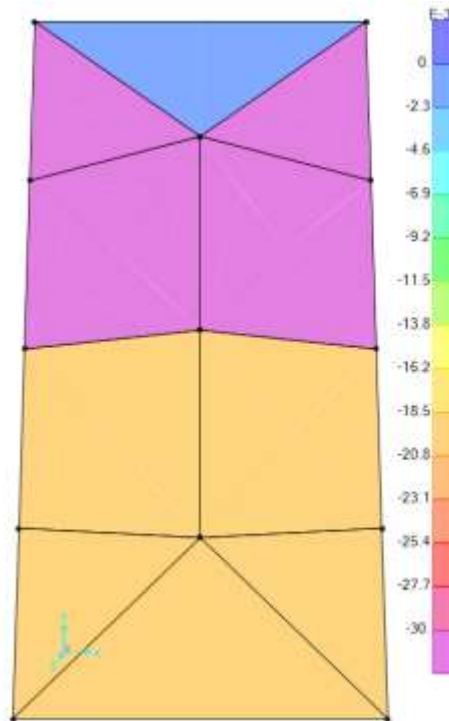

5.3.4 Wind 2(case 2)

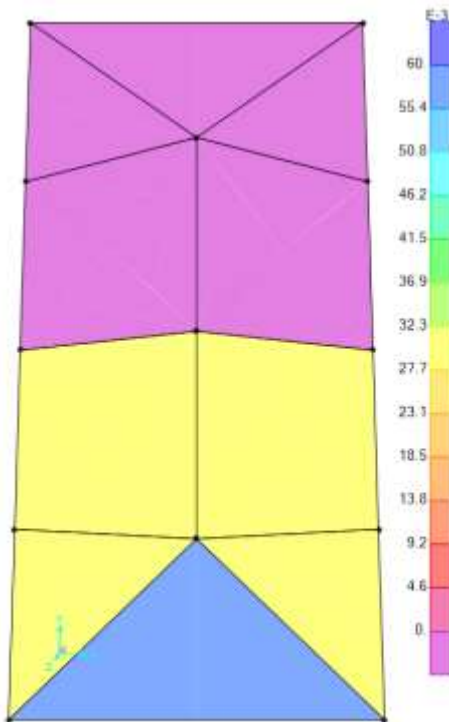

After 3D model analysis, each member is checked based on adverse load combination. In this regard the maximum bending moment, shear and axial force due to adverse load combinations for each member are presented as below:



Civil & Structural Engineering Design Services Pty. Ltd.

5.3.5 Max Bending Moment due to critical load combination in major axis

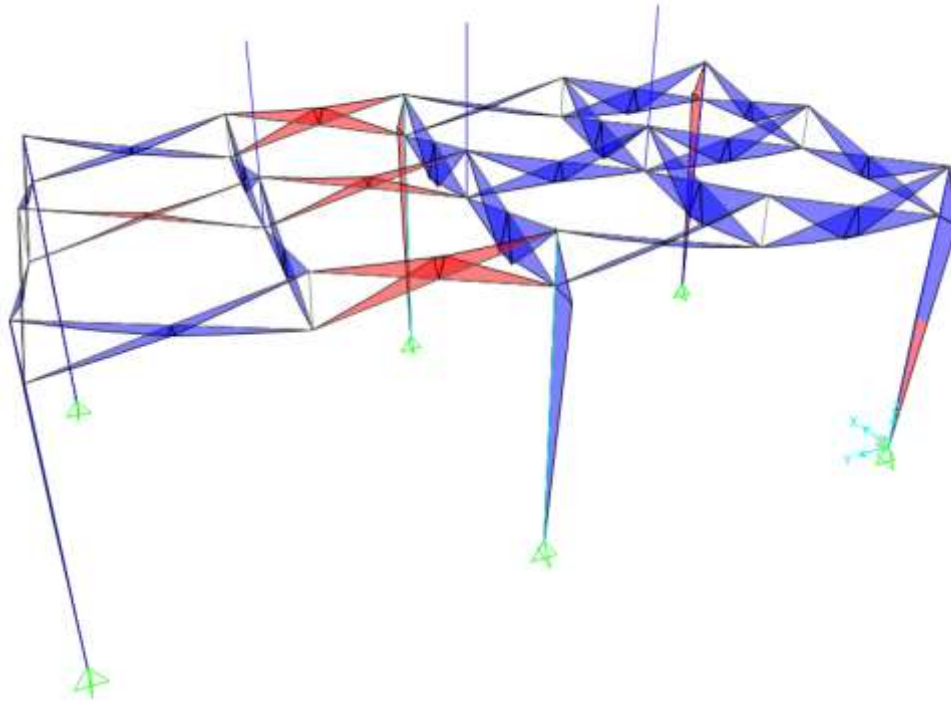

5.3.6 Max Bending Moment in minor axis due to critical load combination

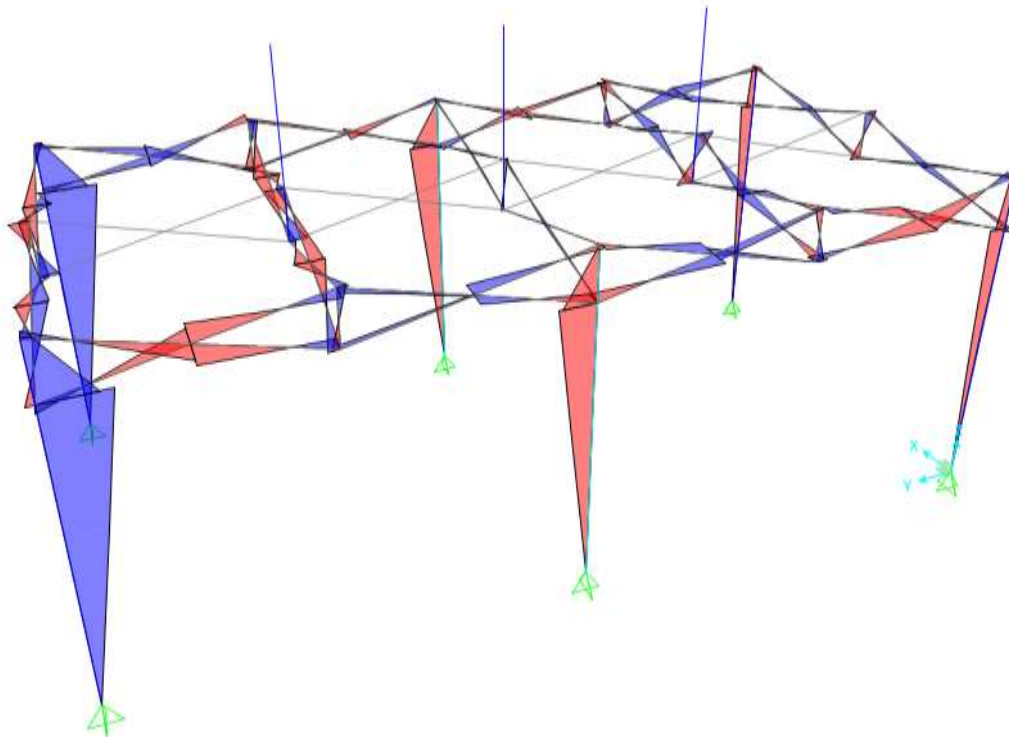



Civil & Structural Engineering Design Services Pty. Ltd.

5.3.7 Max Shear in due to critical load combination

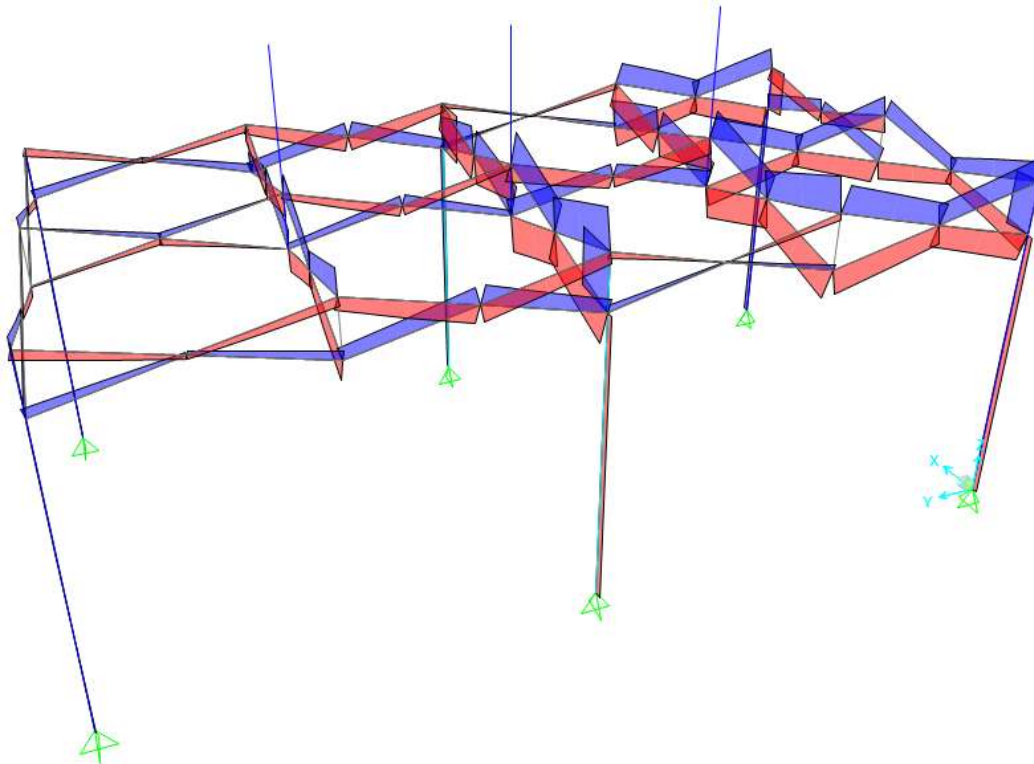

5.3.8 Max Axial force in upright support and roof beam due to critical load combination

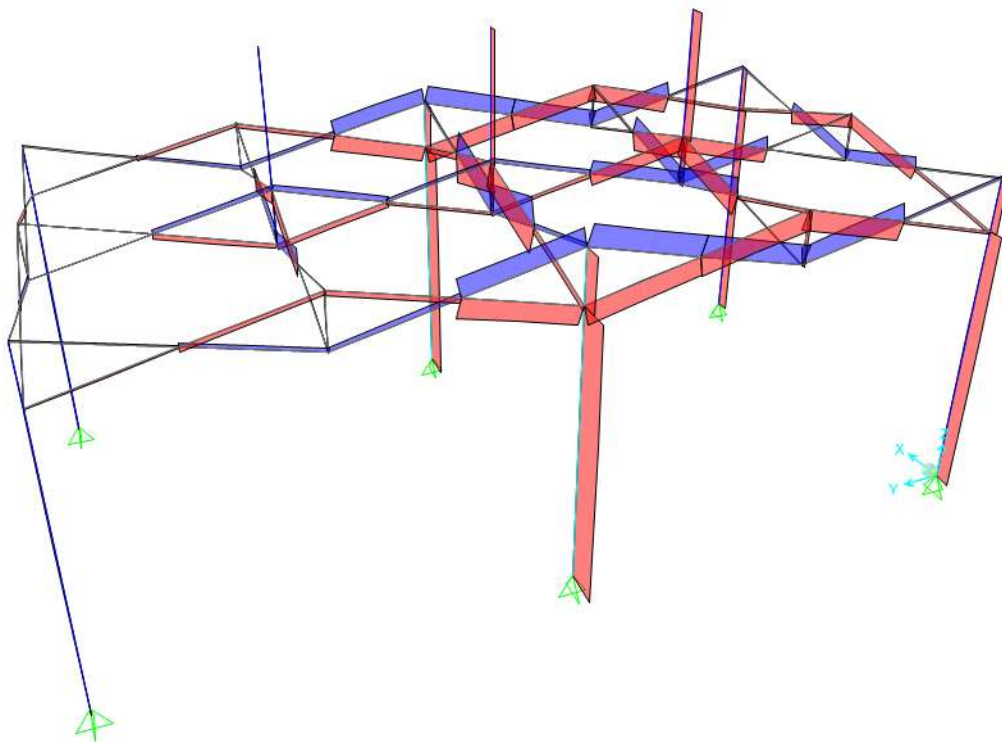



Civil & Structural Engineering Design Services Pty. Ltd.

Axial force	P	=	0.238	kN	<i>compression</i>	
	P	=	0	kN	<i>Tension</i>	
In plane moment	M_x	=	0.0342	kNm		
Out of plane moment	M_y	=	1.454E-05	kNm		
DESIGN STRESSES						
Gross cross section area	A_g	=	71	mm ²		
In-plane elastic section modulus	Z_x	=	450.39333	mm ³		
Out-of-plane elastic section mod.	Z_y	=	296.03667	mm ³		
Stress from axial force	f_a	=	P/A_g			
		=	3.35	MPa	<i>compression</i>	
		=	0.00	MPa	<i>Tension</i>	
Stress from in-plane bending	f_{bx}	=	M_x/Z_x			
		=	75.93	MPa	<i>compression</i>	
Stress from out-of-plane bending	f_{by}	=	M_y/Z_y			
		=	0.05	MPa	<i>compression</i>	
<i>Tension</i>						
3.4.3 Tension in rectangular tubes						
	ϕF_L	=	228.95	MPa		
		OR				
	ϕF_L	=	222.70	MPa		
COMPRESSION						
3.4.8 Compression in columns, axial, gross section						
1. General						
						... 3.4.8.1
Unsupported length of member	L	=	1550	mm		
Effective length factor	k	=	1			
Radius of gyration about buckling axis (Y)	r_y	=	5.10	mm		
Radius of gyration about buckling axis (X)	r_x	=	8.90	mm		
Slenderness ratio	kLb/r_y	=	150.84			
Slenderness ratio	kL/r_x	=	174.06			
Slenderness parameter	λ	=	3.251			
	D_c^*	=	90.3			
	S_1^*	=	0.33			
	S_2^*	=	1.23			
	ϕ_{cc}	=	0.950			



Civil & Structural Engineering Design Services Pty. Ltd.

Factored limit state stress	ϕF_L	=	21.66	MPa	
2. Sections not subject to torsional or torsional-flexural buckling					... 3.4.8.2
Largest slenderness ratio for flexural buckling	kL/r	=	174.06		
3.4.10 Uniform compression in components of columns, gross section - flat plates					
1. Uniform compression in components of columns, gross section - flat plates with both edges supported					... 3.4.10.1 T3.3(D)
	k_1	=	0.35		
Max. distance between toes of fillets of supporting elements for plate	b'	=	10.5		
	t	=	1	mm	
Slenderness	b/t	=	10.5		
Limit 1	S_1	=	12.34		
Limit 2	S_2	=	32.87		
Factored limit state stress	ϕF_L	=	228.95	MPa	
Most adverse compressive limit state stress	F_a	=	21.66	MPa	
Most adverse tensile limit state stress	F_a	=	222.70	MPa	
Most adverse compressive & Tensile capacity factor	f_a/F_a	=	0.15		PASS
BENDING - IN-PLANE					
3.4.15 Compression in beams, extreme fibre, gross section rectangular tubes, box sections					
Unbraced length for bending	L_b	=	770	mm	
Second moment of area (weak axis)	I_y	=	1.85E+03	mm ⁴	
Torsion modulus	J	=	4.29E+03	mm ³	
Elastic section modulus	Z	=	450.39333	mm ³	
Slenderness	S	=	246.14		
Limit 1	S_1	=	0.39		
Limit 2	S_2	=	1695.86		
Factored limit state stress	ϕF_L	=	194.40	MPa	... 3.4.15(2)
3.4.17 Compression in components of beams (component under uniform compression), gross section - flat plates with both edges supported					
	k_1	=	0.5		T3.3(D)



Civil & Structural Engineering Design Services Pty. Ltd.

	k_2	=	2.04			T3.3(D)
Max. distance between toes of fillets of supporting elements for plate	b'	=	10.5	mm		
	t	=	1	mm		
Slenderness	b/t	=	10.5			
Limit 1	S_1	=	12.34			
Limit 2	S_2	=	46.95			
Factored limit state stress	ϕF_L	=	228.95	MPa		
Most adverse in-plane bending limit state stress	F_{bx}	=	194.40	MPa		
Most adverse in-plane bending capacity factor	f_{bx}/F_{bx}	=	0.39		PASS	
BENDING - OUT-OF-PLANE						
<i>NOTE: Limit state stresses, ϕF_L are the same for out-of-plane bending (doubly symmetric section)</i>						
Factored limit state stress	ϕF_L	=	194.40	MPa		
Most adverse out-of-plane bending limit state stress	F_{by}	=	194.40	MPa		
Most adverse out-of-plane bending capacity factor	f_{by}/F_{by}	=	0.00		PASS	
COMBINED ACTIONS						
4.1.1 Combined compression and bending						
	F_a	=	21.66	MPa		... 4.1.1(2)
	F_{ao}	=	228.95	MPa		... 3.4.8
	F_{bx}	=	194.40	MPa		... 3.4.10
	F_{by}	=	194.40	MPa		... 3.4.17
	f_a/F_a	=	0.155			... 3.4.17
	Check: $f_a/F_a + f_{bx}/F_{bx} + f_{by}/F_{by} \leq 1.0$... 4.1.1 (3)
	i.e. 0.55	\leq	1.0		PASS	
SHEAR						
3.4.24 Shear in webs (Major Axis)						
Clear web height	h	=	23	mm		... 4.1.1(2)



Civil & Structural Engineering Design Services Pty. Ltd.

	t	=	1	mm		
Slenderness	h/t	=	23			
Limit 1	S ₁	=	29.01			
Limit 2	S ₂	=	59.31			
Factored limit state stress	ϕF_L	=	131.10	MPa		
Stress From Shear force	f _{sx}	=	V/A _w			
			0.73	MPa		
3.4.25 Shear in webs (Minor Axis)						
Clear web height	b	=	10.5	mm		
	t	=	1	mm		
Slenderness	b/t	=	10.5			
Factored limit state stress	ϕF_L	=	131.10	MPa		
Stress From Shear force	f _{sy}	=	V/A _w			
			0.01	MPa		

6.2 Upright Supports (outer)

NAME	SYMBOL	VALUE	UNIT	NOTES	REF
HEX45x40x1	Upright Support				
Alloy and temper	6061-T6				AS1664.1
Tension	F _{tu}	=	262	MPa	Ultimate
	F _{ty}	=	241	MPa	Yield
Compression	F _{cy}	=	241	MPa	
Shear	F _{su}	=	165	MPa	Ultimate
	F _{sy}	=	138	MPa	Yield
Bearing	F _{bu}	=	551	MPa	Ultimate
	F _{by}	=	386	MPa	Yield
Modulus of elasticity	E	=	70000	MPa	Compressive
	k _t	=	1.0		
	k _c	=	1.0		
FEM ANALYSIS RESULTS					
Axial force	P	=	0.241	kN	compression
	P	=	0	kN	Tension
In plane moment	M _x	=	0.1503	kNm	



Civil & Structural Engineering Design Services Pty. Ltd.

Out of plane moment	M_y	=	0.0021	kNm		
DESIGN STRESSES						
Gross cross section area	A_g	=	135.1	mm ²		
In-plane elastic section modulus	Z_x	=	1236.62	mm ³		
Out-of-plane elastic section mod.	Z_y	=	1427.9	mm ³		
Stress from axial force	f_a	=	P/A_g			
		=	1.78	MPa	compression	
		=	0.00	MPa	Tension	
Stress from in-plane bending	f_{bx}	=	M_x/Z_x			
		=	121.54	MPa	compression	
Stress from out-of-plane bending	f_{by}	=	M_y/Z_y			
		=	1.47	MPa	compression	
Tension						
3.4.3 Tension in rectangular tubes						
	ϕF_L	=	228.95	MPa		
		OR				
	ϕF_L	=	222.70	MPa		
COMPRESSION						
3.4.8 Compression in columns, axial, gross section						
1. General						
						... 3.4.8.1
Unsupported length of member	L	=	2370	mm		
Effective length factor	k	=	1			
Radius of gyration about buckling axis (Y)	r_y	=	14.54	mm		
Radius of gyration about buckling axis (X)	r_x	=	14.54	mm		
Slenderness ratio	kL_b/r_y	=	137.55			
Slenderness ratio	kL/r_x	=	163.00			
Slenderness parameter	λ	=	3.04			
	D_c^*	=	90.3			
	S_1^*	=	0.33			
	S_2^*	=	1.23			
	ϕ_{cc}	=	0.950			
Factored limit state stress	ϕF_L	=	24.70	MPa		
2. Sections not subject to torsional or torsional-flexural buckling						
						... 3.4.8.2



Civil & Structural Engineering Design Services Pty. Ltd.

Largest slenderness ratio for flexural buckling	kL/r	=	163.00		
3.4.10 Uniform compression in components of columns, gross section - flat plates					
<i>1. Uniform compression in components of columns, gross section - flat plates with both edges supported</i>					
	k_1	=	0.35		... 3.4.10.1 T3.3(D)
Max. distance between toes of fillets of supporting elements for plate	b'	=	43		
	t	=	1	mm	
Slenderness	b/t	=	43		
Limit 1	S_1	=	12.34		
Limit 2	S_2	=	32.87		
Factored limit state stress	ϕF_L	=	130.67	MPa	
Most adverse compressive limit state stress	F_a	=	24.70	MPa	
Most adverse tensile limit state stress	F_a	=	222.70	MPa	
Most adverse compressive & Tensile capacity factor	f_a/F_a	=	0.07		PASS
BENDING - IN-PLANE					
3.4.15 Compression in beams, extreme fibre, gross section rectangular tubes, box sections					
Unbraced length for bending	L_b	=	2000	mm	
Second moment of area (weak axis)	I_y	=	2.86E+04	mm ⁴	
Torsion modulus	J	=	5.18E+04	mm ³	
Elastic section modulus	Z	=	1236.62	mm ³	
Slenderness	S	=	128.59		
Limit 1	S_1	=	0.39		
Limit 2	S_2	=	1695.86		
Factored limit state stress	ϕF_L	=	204.37	MPa	... 3.4.15(2)
3.4.17 Compression in components of beams (component under uniform compression), gross section - flat plates with both edges supported					
	k_1	=	0.5		T3.3(D)
	k_2	=	2.04		T3.3(D)



Civil & Structural Engineering Design Services Pty. Ltd.

Max. distance between toes of fillets of supporting elements for plate	b'	=	43	mm		
	t	=	1	mm		
Slenderness	b/t	=	43			
Limit 1	S_1	=	12.34			
Limit 2	S_2	=	46.95			
Factored limit state stress	ϕF_L	=	142.89	MPa		
Most adverse in-plane bending limit state stress	F_{bx}	=	142.89	MPa		
Most adverse in-plane bending capacity factor	f_{bx}/F_{bx}	=	0.85		PASS	
BENDING - OUT-OF-PLANE						
<i>NOTE: Limit state stresses, ϕF_L are the same for out-of-plane bending (doubly symmetric section)</i>						
Factored limit state stress	ϕF_L	=	142.89	MPa		
Most adverse out-of-plane bending limit state stress	F_{by}	=	142.89	MPa		
Most adverse out-of-plane bending capacity factor	f_{by}/F_{by}	=	0.01		PASS	
COMBINED ACTIONS						
4.1.1 Combined compression and bending						
	F_a	=	24.70	MPa		... 4.1.1(2)
	F_{ao}	=	130.67	MPa		... 3.4.8
	F_{bx}	=	142.89	MPa		... 3.4.10
	F_{by}	=	142.89	MPa		... 3.4.17
	f_a/F_a	=	0.072			... 3.4.17
Check:	$f_a/F_a + f_{bx}/F_{bx} + f_{by}/F_{by} \leq 1.0$... 4.1.1 (3)
i.e.	0.93	\leq	1.0		PASS	
SHEAR						
3.4.24 Shear in webs (Major Axis)						
						... 4.1.1(2)
Clear web height	h	=	38	mm		
	t	=	1	mm		



Civil & Structural Engineering Design Services Pty. Ltd.

Slenderness	h/t	=	38		
Limit 1	S_1	=	29.01		
Limit 2	S_2	=	59.31		
Factored limit state stress	ϕF_L	=	122.00	MPa	
Stress From Shear force	f_{sx}	=	V/A_w		
			0.38	MPa	
3.4.25 Shear in webs (Minor Axis)					
Clear web height	b	=	43	mm	
	t	=	1	mm	
Slenderness	b/t	=	43		
Factored limit state stress	ϕF_L	=	116.93	MPa	
Stress From Shear force	f_{sy}	=	V/A_w		
			0.01	MPa	



Civil & Structural Engineering Design Services Pty. Ltd.

7 Summary

7.1 Conclusions

- a. The 3m x 6m Folding Marquees Structure as specified has been analyzed with a conclusion that it has the capacity to withstand wind speeds up to and including **45km/hr**.
- b. For forecast winds in excess of **45km/hr** – the structure should be completely folded.
- c. For uplift due to 45km/hr, 0.5 kN (50kg) holding down weight/per leg for upright support is required.
- d. The bearing pressure of soil should be clarified and checked by an engineer prior to any construction for considering foundation and base plate.
- e. **No Fabrics or doors should be used for covering the sides of unbraced Folding Marquees due to the lack of bracing within the system and insufficient out-of-plane stiffness of framing.**

Yours faithfully,

E.A. Bennett M.I.E. Aust. NPER 198230



Civil & Structural Engineering Design Services Pty. Ltd.

8 Appendix A – Base Anchorage Requirements

3m x 6m 45mm Folding Marquees:

Tent Span	Soil Type	Required Weight Per Leg
3 m	A	50kg
	B	50kg
	C	50kg
	D	50kg
	E	50kg

Definition of Soil Types:

Type A : Loose sand such as dunal sand. Uncompacted site filling may also be included in this soil type.

Type B : Medium to stiff clays or silty clays

Type C: Moderately compact sand or gravel eg. of alluvial origin.

Type D : Compact sand and gravel eg. Weathered sandstone or compacted quarry rubble hardstand

Type E : Concrete slab on ground .